

VALVE BLOCKS FOR HKU AND XY TYPE BKH...

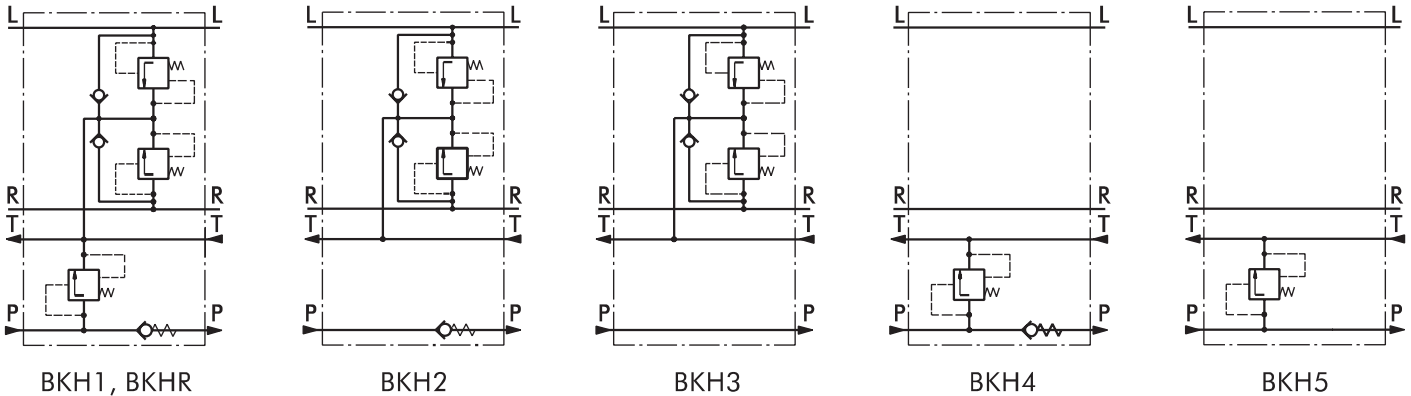

The M+S Hydraulic BKH valves are developed to protect the components of the hydraulic circuit: pumps, steering units and cylinders - from overloads, impacts and cavitation. Some of their advantages are: easy integration into any hydraulic circuit, easy mounting to the steering unit, and quick and easy hose connections. Depending on the design and the built in valves the BKH valves can be divided into 6 types: BKH1 ... BKH5 and BKHR, with BKH5 designed for XY steering units only. The maximum flow rate is in compliance with the whole range of HKU and XY steering units but no more than 80 l/min. The pressure settings for the entry relief valves and the shock valves are given in the table.



SPECIFICATION DATA

Parameters	Type										
	BKH1, BKHR				BKH2	BKH3	BKH4, BKH5				
Rated Flow	lpm [GPM]	80 [21.1]									
Rated Pressure	bar [PSI]	160 [2320]									
Relief Valve Pressure Settings*	bar [PSI]	80 [1160]	100 [1450]	125 [1810]	150 [2175]	-	-	80 [1160]	100 [1450]	125 [1810]	150 [2175]
Shock Valves Pressure Settings**	bar [PSI]	140 [2030]	160 [2320]	180 [2610]	200 [2900]	200 [2900]	240 [3480]	-	-	-	-
Weight	kg [lb]	1,8 , 2,3 [4.0] , [5.1]				1,8 [4.0]		1,8 [4.0]			

* Pressure Settings are at flow rate of 30 lpm [7.92 GPM] and viscosity 21 mm²/s [105 SUS] at 50° C [122°F].

** Pressure Settings are at flow rate of 2 lpm [.53 GPM] and viscosity 21 mm²/s [105 SUS] at 50° C [122°F].

DIMENSIONS AND MOUNTING DATA - BKH1, 2, 3, 4

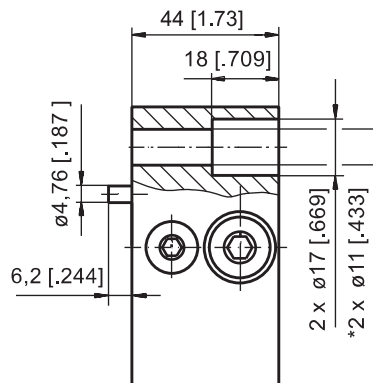
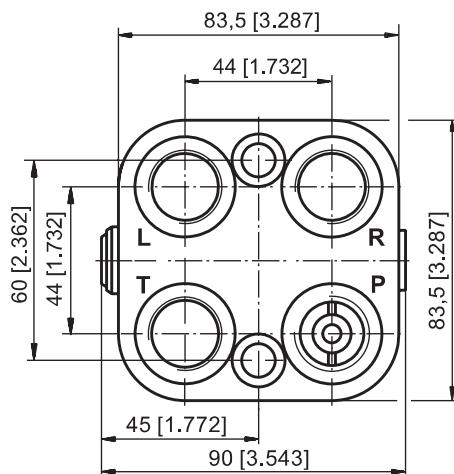

Code	Ports - P, T, R, L Thread
-	G1/2 20 [.80] depth
M	M22x1,5 20 [.80] depth
A	3/4 - 16 UNF O-ring 20 [.80] depth

* Connection to the HKU is done with 2 screws M10x1x40 -8.8 DIN 912 or with 2 screws 3/8-24 UNF ANSI B18.3-76, long 1.5". Tightening torque: 2,5±0,5 daNm [177±265 lb - in].

DIMENSIONS AND MOUNTING DATA - BKHR

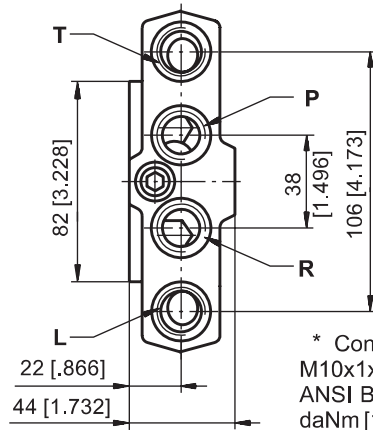
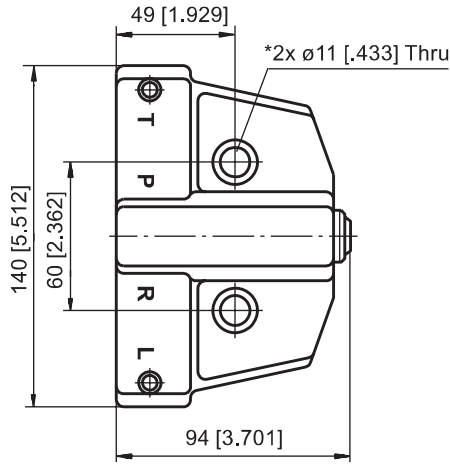

Code	Ports - P, T, R, L Thread
M	M18x1,5 22 [.87] depth
A	3/4 - 16 UNF O-ring 22 [.87] depth

* Connection to the HKU is done with 2 screws M10x1x40 -8.8 DIN 912 or with 2 screws 3/8-24 UNF ANSI B18.3-76, long 1.5". Tightening torque: 2,5±0,5 daNm [177±265 lb-in].

DIMENSIONS AND MOUNTING DATA - BKH5

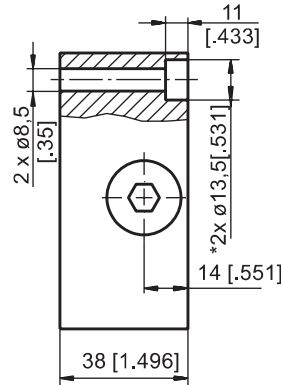
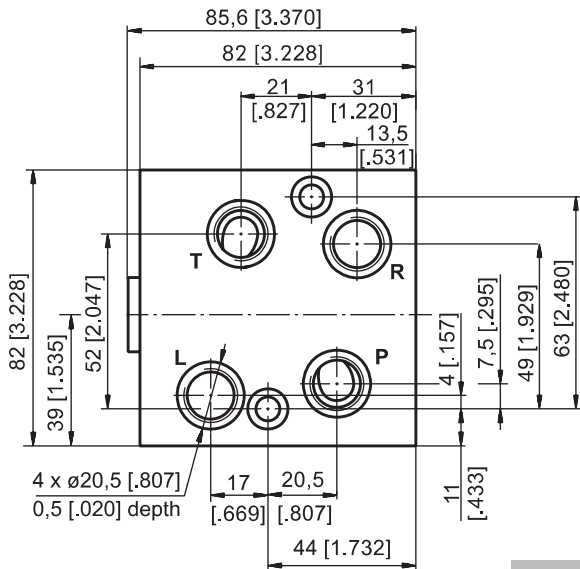

Code	Ports - P, T, R, L Thread
M	M16x1,5 14 [.55] depth

* Connection to the XY is done with 2 screws M8x1x40 -8.8 DIN 912. Tightening torque: 2,5±0,5 daNm [177±265 lb-in].

ORDER CODE

1	2	3	4	5
BKH	-	-		

Pos.1 - Versions*

R	1	2	3	4	
•	•			•	- Input relief valve on line "P"
•	•	•		•	- Input check (non-return) valve on line "P"
•	•	•	•		- Shock valves on lines "R" and "L"
•	•	•	•		- Anti-cavitation valves on lines "R" and "L"

Pos.2 - Relief Valve Pressure Settings, bar**

80	100	125	150
-----------	------------	------------	------------

Pos.3 - Ports***

omit	- BSPP (ISO 228)
A	- SAE (ANSI B 1.1 - 1982)
M	- Metric (ISO 262)

Pos.4 - Option (Paint)****

omit	- No Paint
P	- Painted Low Gloss Color
PC	- Corrosion Protected Paint

Pos.5 - Design Series

omit	- Factory specified
------	---------------------

Notes: * Versions **R, 1, 2, 3, 4** -for HKU; **5** - for XY.
** That does not concern version 2 and 3.
*** For Port size see drawings on page 19 and 20.
**** Colour at customer's request.

The valve blocks are mangano-phosphatized as standard.