

PRIORITY VALVES FOR HKUS.../5... TYPE PR...



The Priority Valves distribute and trace the hydraulic flow from the supply pump of the hydraulic system to the hydraulic components which control and run the vehicle. The Priority Valves are used only with the HKUS.../5(D)(T) hydrostatic steering units. When connected, the steering unit and the priority valve represent sophisticated hydraulic tracing system that controls the flow in both main pipelines of the hydraulic system (the working and control one) at any time of its operation.



As a static signal, the "LS" signal must be used in systems with circuit stability. The connection between the PRT, PRTA priority valves and the HKUS.../5T steering units has to be as short as possible, but should not exceed 1,5 m [4.92 ft] (for iron pipe with 4 mm [.157 in.] internal diameter). When a rubber hose is used this length have to be even shorter.

Priority valves with dynamic signal work in a system with dynamic hydrostatic steering units type HKUS.../5D (5DT).

Modulary Mounting

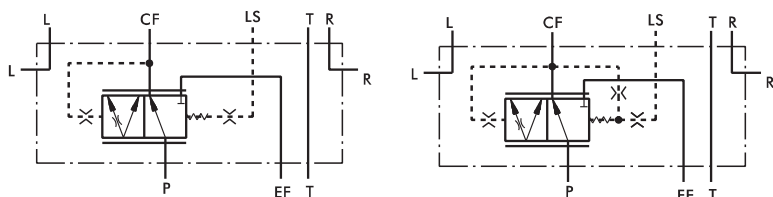

Static signal
PRD 40,80/...

Dynamic signal
PRDD 40,80/...

Pipe Mounting

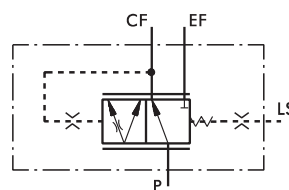

Static signal
PRT 40,80,120/..., PRTA 40,80/...

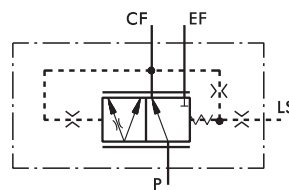

Dynamic signal
PRTD 40,80,120/..., PRTAD 40,80/...

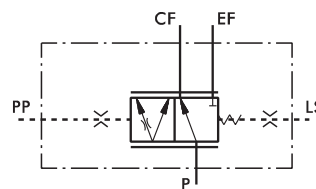

Static signal with External Port
PRTE120/...

PR...40

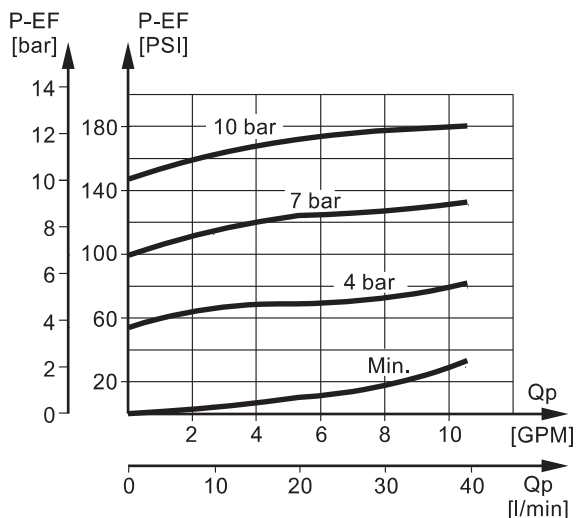

PR...80

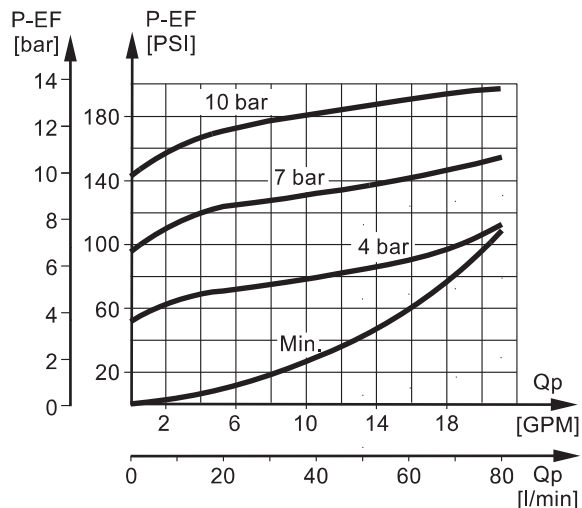

PRT...120

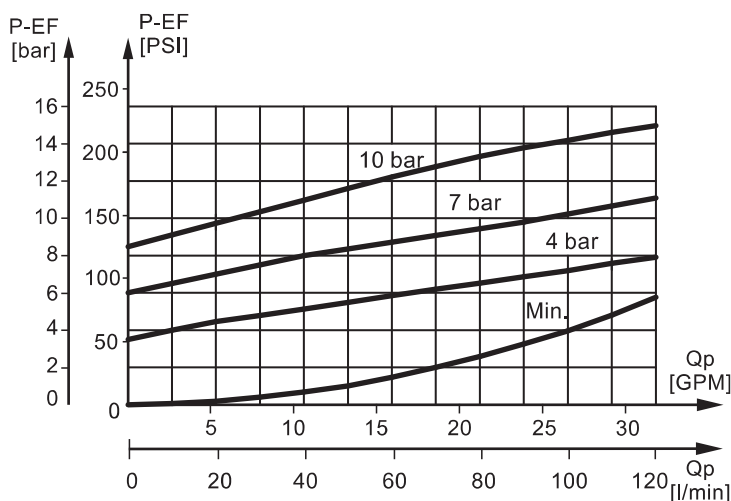

SPECIFICATION DATA

Parameters		Type								
		PRD(D), PRT(D)			PRTA(D)			PRT(D)(E)		
Rated Flow	lpm [GPM]	40 [10.6]			80 [21.1]			120 [31.7]		
Control Spring Pressure	bar [PSI]	4 [58]	7 [101.5]	10 [145]	4 [58]	7 [101.5]	10 [145]	4 [58]	7 [101.5]	10 [145]
Max. Pressures in Oil Ports:	P, EF	250 [3625]								
	CF	210 [3045]								
	R, L	280 [4061]			-					
	LS	210 [3045]								
	PP							210 [3045]		
	T	20 [290]								
Weight	kg [lb]	2,25 [4.96]			1,3 [2.87]			2,1 [4.6]		

P - pump, EF - excess flow, CF - control flow (first priority oil flow),
L - left, R - right, LS - load sensing, T - tank, PP - pilot pressure (L,R and T - for PRD(D) only).

DIMENSIONS AND MOUNTING DATA - PRD(D) 40, 80/...

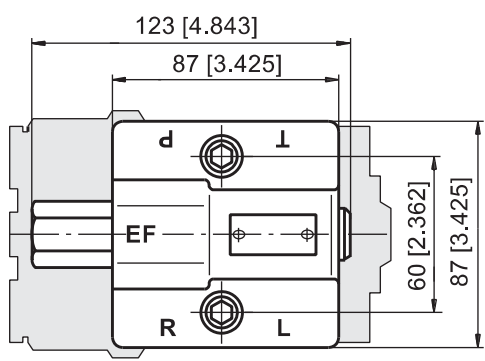
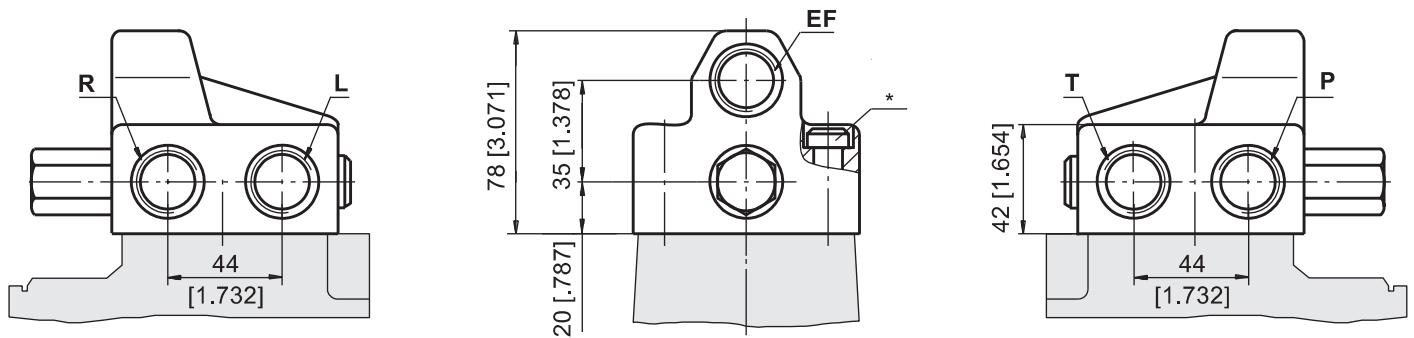

Code	Ports - P, EF Thread	Ports - T, R, L Thread
-	G1/2 18 [.71] depth	G3/8 18 [.71] depth
M	M22x1,5 18 [.71] depth	M18x1,5 18 [.71] depth
A	7/8 - 14 UNF O-ring 18 [.71] depth	3/4 - 16 UNF O-ring 18 [.71] depth

* Connection to the HKUS.../5(D)... is done with 2 screws M10x1x45 -10.9 DIN 912 or with 2 screws 3/8-24 UNF ANSI B18.3-76, 1.75" long.
Tightening torque: 4,5±0,5 daNm [360 ± 440 lb-in].



DIMENSIONS AND MOUNTING DATA - PRT(D) 40, 80/...

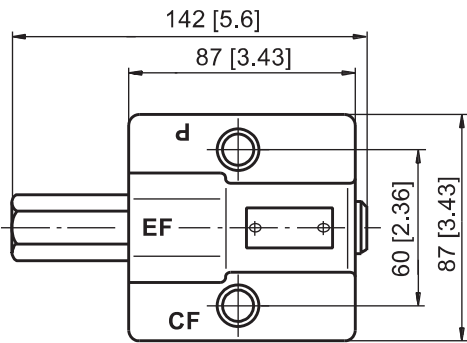
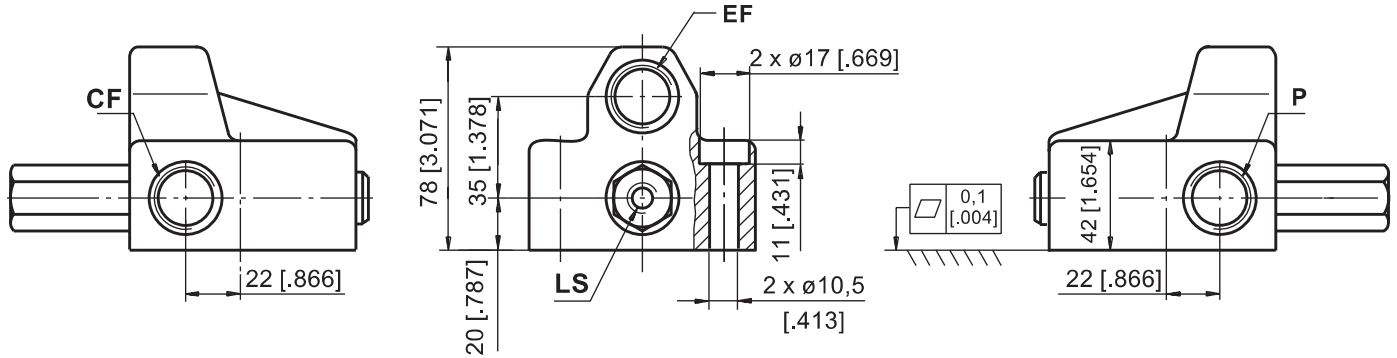

code	Ports - P, EF Thread	Port - CF Thread	LS - Port
-	G1/2 18 mm [.71] depth	G1/2 18 mm [.71] depth	G1/4 14 mm [.55] depth
M	M 22x1,5 18 mm [.71] depth	M 22x1,5 18 mm [.71] depth	G1/4 14 mm [.55] depth
A	7/8 - 14 UNF O-ring 18 [.71] depth	3/4 - 16 UNF O-ring 18 [.71] depth	7/16 - 20 UNF O-ring 12,7 [.50] depth

DIMENSIONS AND MOUNTING DATA - PRTA(D) 40, 80/...

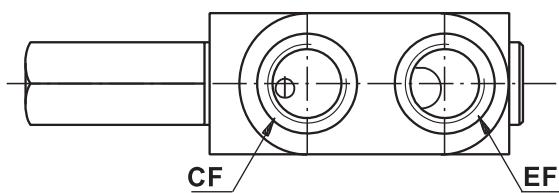
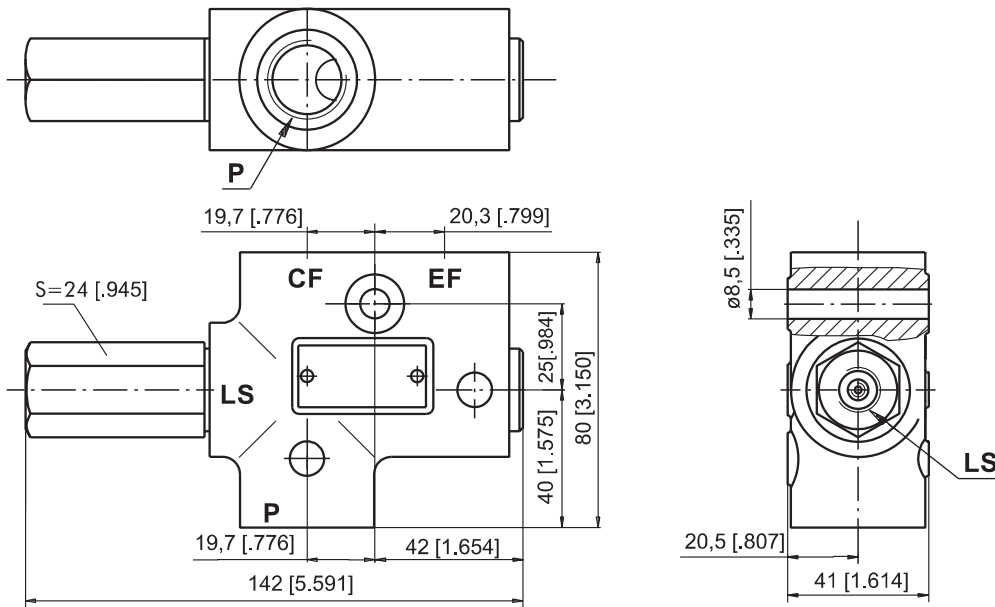

code	Ports - P, EF Thread	Port - CF Thread	LS - Port
-	G1/2 18 mm [.71] depth	G1/2 18 mm [.71] depth	G1/4 14 mm [.55] depth
M	M 22x1,5 18 mm [.71] depth	M 22x1,5 18 mm [.71] depth	G1/4 14 mm [.55] depth
A	7/8 - 14 UNF O-ring 18 [.71] depth	3/4 - 16 UNF O-ring 18 [.71] depth	7/16 - 20 UNF O-ring 12,7 [.50] depth



DIMENSIONS AND MOUNTING DATA - PRT...120/...

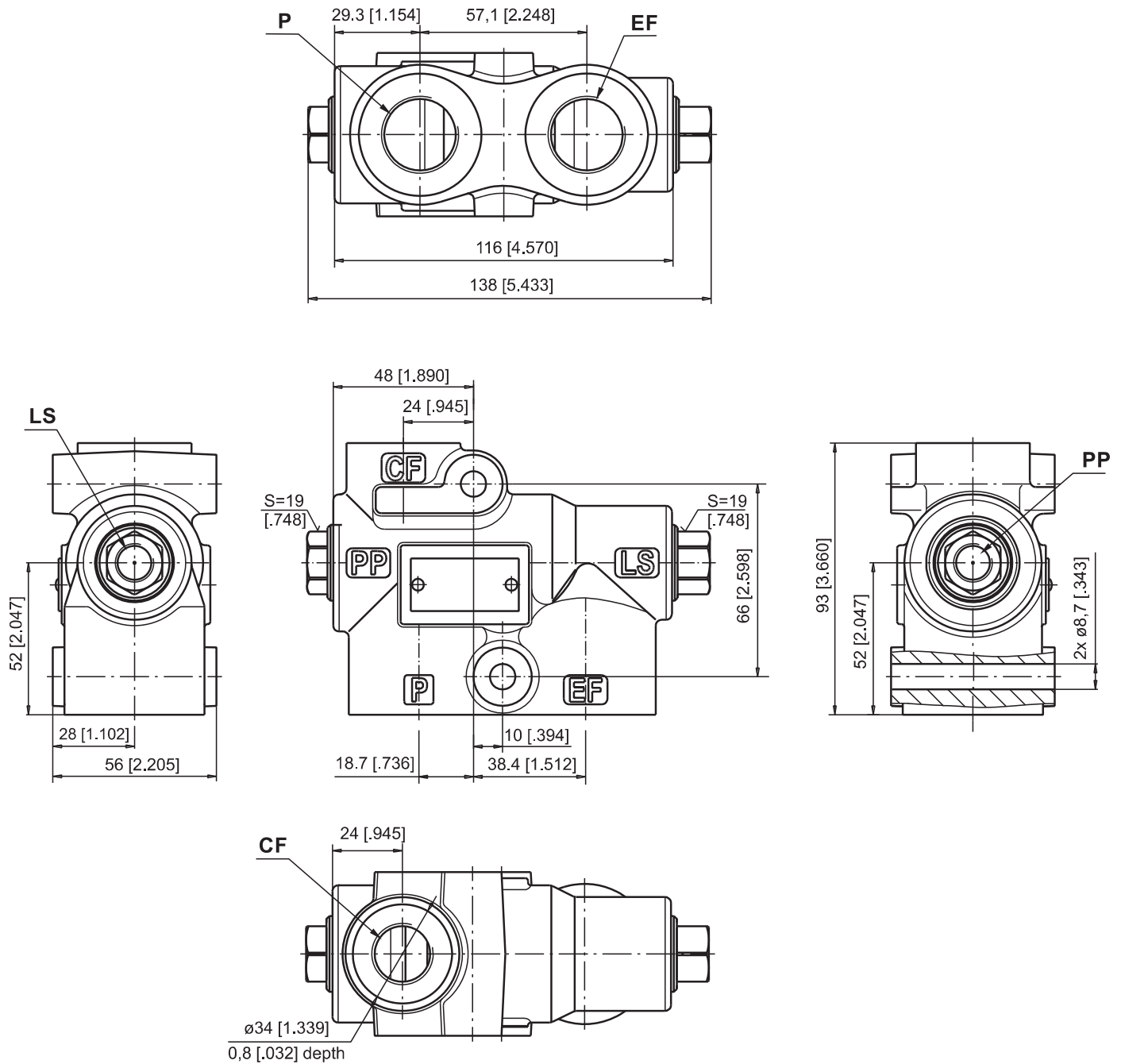

Code	Ports - P, EF Thread	Port - CF Thread	LS, PP - Ports
-	G3/4 20,5 [.81] depth	G1/2 18,5 [.73] depth	G1/4 12,5 [.49] depth
M	M27x2 20,5 [.81] depth	M18x1,5 18,5 [.73] depth	M12x1,5 12,5 [.49] depth
A	1 1/16 - 12 UN O-ring 20,5 [.81] depth	3/4 - 16 UNF O-ring 18,5 [.73] depth	7/16 - 20 UNF O-ring 12,5 [.49] depth



PRIORITY VALVES FOR HKU(S).../5T... TYPE PRT...160/... —



The Priority Valves PRT...160 have built-in a pilot pressure relief valve, who protects the steering unit against excess pressure. The pilot pressure relief valve operates with the Shuttle of the Priority valve to limit the maximum steering pressure P-T measured across the steering units ports.

SPECIFICATION DATA

Parameters		Type		
		PRT(D), PRTE		
Rated Flow	lpm [GPM]	160 [42.3]		
Control Spring Pressure	bar [PSI]	4 [58]	7 [101.5]	10 [145]
Max. Pressures in Oil Ports:	P, EF	350 [5076]		
	CF	210 [3045]		
	LS	210 [3045]		
	PP	210 [3045]		
	T	15 [217]		
Standart Relief Valve Pressure Settings	bar [PSI] *	175 [2540]		
Weight	kg [lb]	4,4 [9.70]		

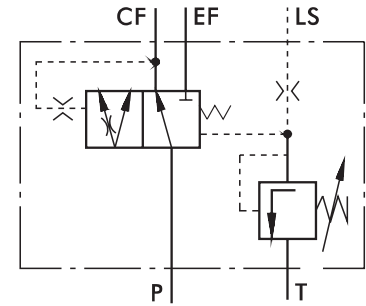

Static signal
PRT 160/...

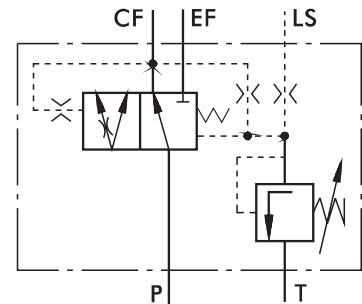

Dynamic signal
PRTD 160/...

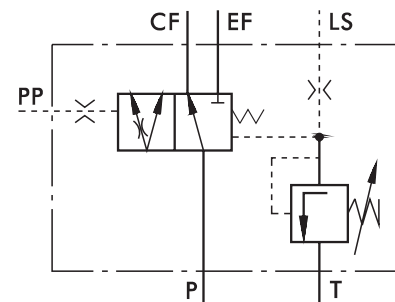

Static signal with External Pilot
PRTE 160/...

* - Adjusted valve pressure from 80 bar [1160 PSI] till 210 bar [3045 PSI] upon customer request.

P - pump, **EF** - excess flow, **CF** - control flow (first priority oil flow),
LS - load sensing, **T** - tank, **PP** - pilot pressure

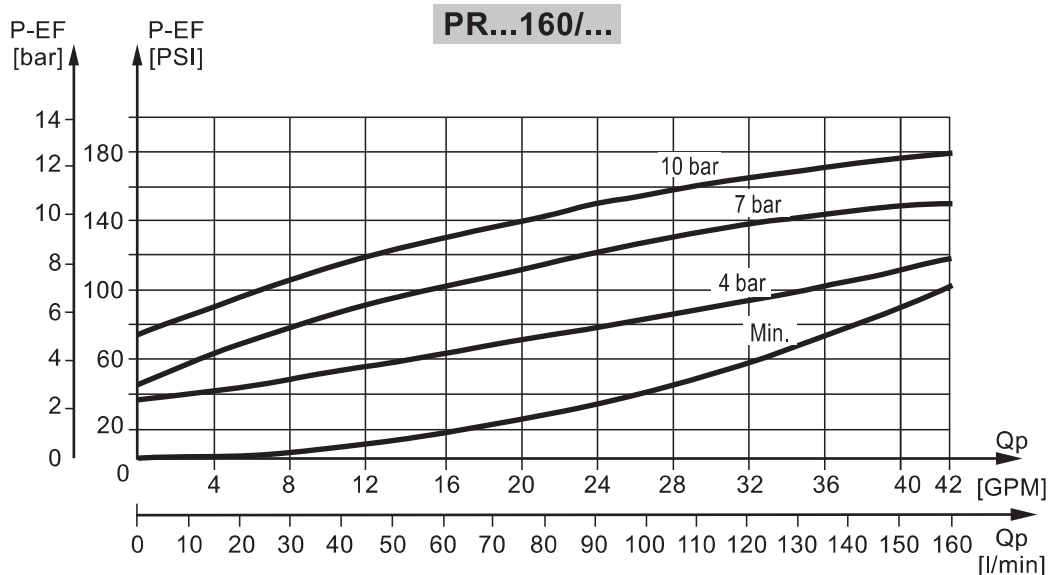

DIMENSIONS AND MOUNTING DATA - PRT(D)(E)160/...

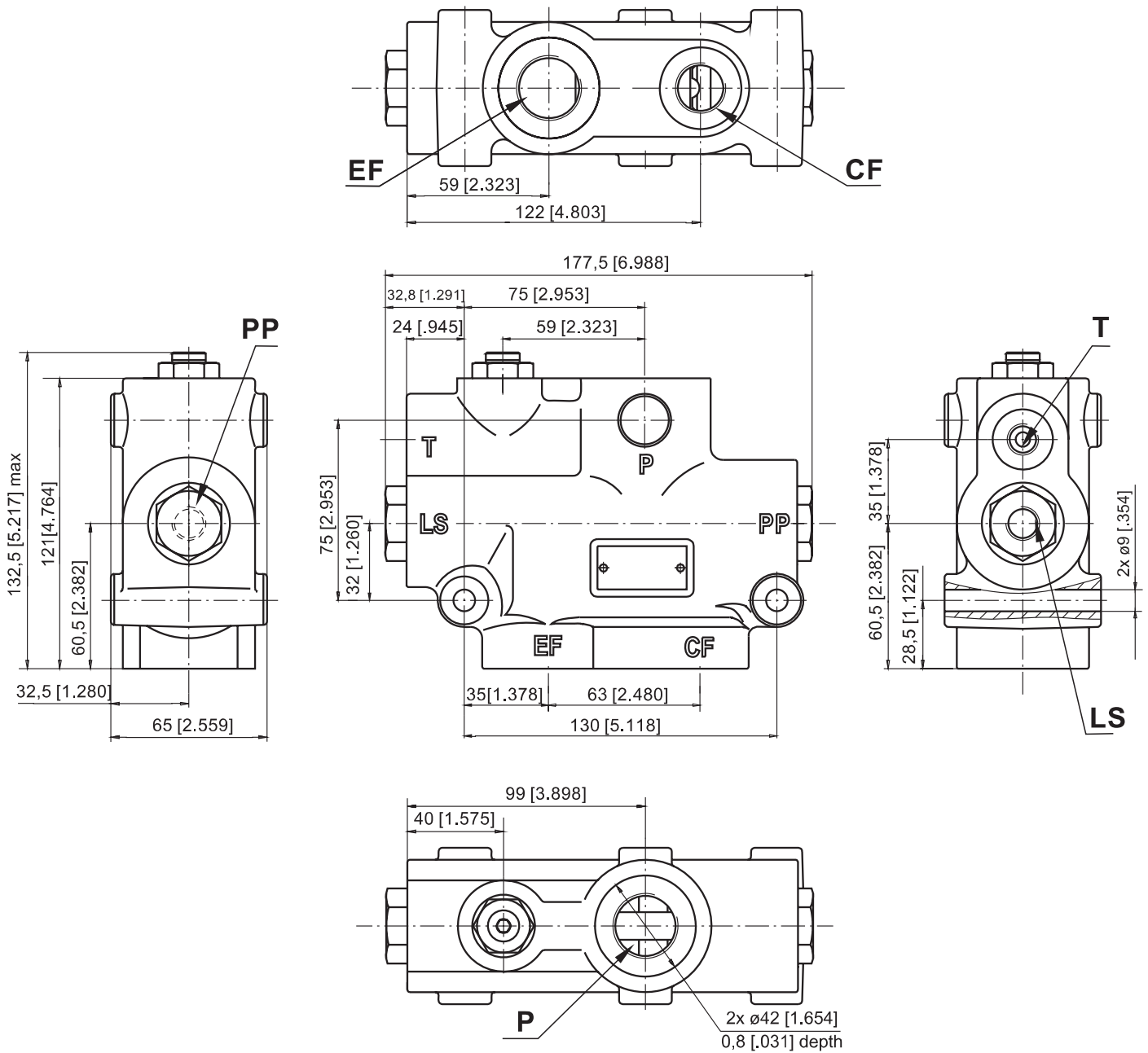

Code	Ports - P, EF Thread	Port - CF Thread	LS, PP, T - Ports
-	G3/4 20,5 [.81] depth	G1/2 18,5 [.73] depth	G1/4 12,5 [.49] depth
M	M27x2 20,5 [.81] depth	M18x1,5 18,5 [.73] depth	M12x1,5 12,5 [.49] depth
A	1 1/16 - 12 UN O-ring 20,5 [.81] depth	3/4 - 16 UNF O-ring 18,5 [.73] depth	7/16 - 20 UNF O-ring 12,5 [.49] depth

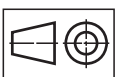

mm [in]

ORDER CODE

	1	2	3	4	5	6	7
PR				/	-		

Pos.1 - Mounting

- D** - Modularly Mounting
- T** - Pipe Mounting (Model 1)
- TA** - Pipe Mounting (Model 2)

Pos.2 - Signal Type

- omit - with Static signal
- D** - with Dynamic signal
- E*** - with Static signal and External Pilot

Pos.3 - Rated Flow, l/min

40	80	120**	160**
-----------	-----------	--------------	--------------

Pos.4 - Control Spring Pressure , bar

4	7	10
----------	----------	-----------

Pos.5 - Ports

- omit - BSPP (ISO 228)
- M** - Metric (ISO 262)
- A** - SAE (ANSI B 1.1 - 1982)

Pos.6 - Option [Paint]***

- omit - No Paint
- P** - Painted Low Gloss Color
- PC** - Corrosion Protected Paint

Pos.7 - Design Series

- omit - Factory specified

Notes: * For PRT 120/... and PRT 160/... only
 ** For PRT only
 *** Colour at customer's request.

The priority valves are mangano-phosphatized as standard.